

**REPAIR PARTS MANUAL**  
**MODEL NO. M11597 (96011023409)**  
**LAWN TRACTOR**

---



**McCULLOCH**

[www.mcculloch.biz](http://www.mcculloch.biz)

# HOW TO USE THIS MANUAL

This manual is designed to provide the customer with a means to identify the parts on his/her tractor when ordering repair parts. The illustrations may or may not represent the actual assemblies; therefore, it is not recommended to use this manual as a guide to assemble or disassemble the tractor. Some hardware and parts are drawn larger in order to more readily identify them.

Each tractor has its own model number.

The model number for your tractor can be found on the fender under the seat.

When ordering parts, always give the following information:

- Product - "Tractor"
- Model Number - "M11597 96011023409"
- Part Number
- Part Description

## TABLE OF CONTENTS

SCHEMATIC .....	3
ELECTRICAL.....	4-5
CHASSIS .....	6-7
DRIVE.....	8-9
ENGINE.....	10-11
STEERING .....	12-13
MOWER DECK .....	14-15
MOWER LIFT.....	16
SEAT .....	17
DECALS.....	18

# TRACTOR -- MODEL NUMBER M11597 (96011023409), PRODUCT NO. 960 11 02-34 SCHEMATIC

SCH01

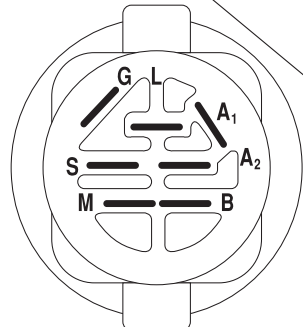
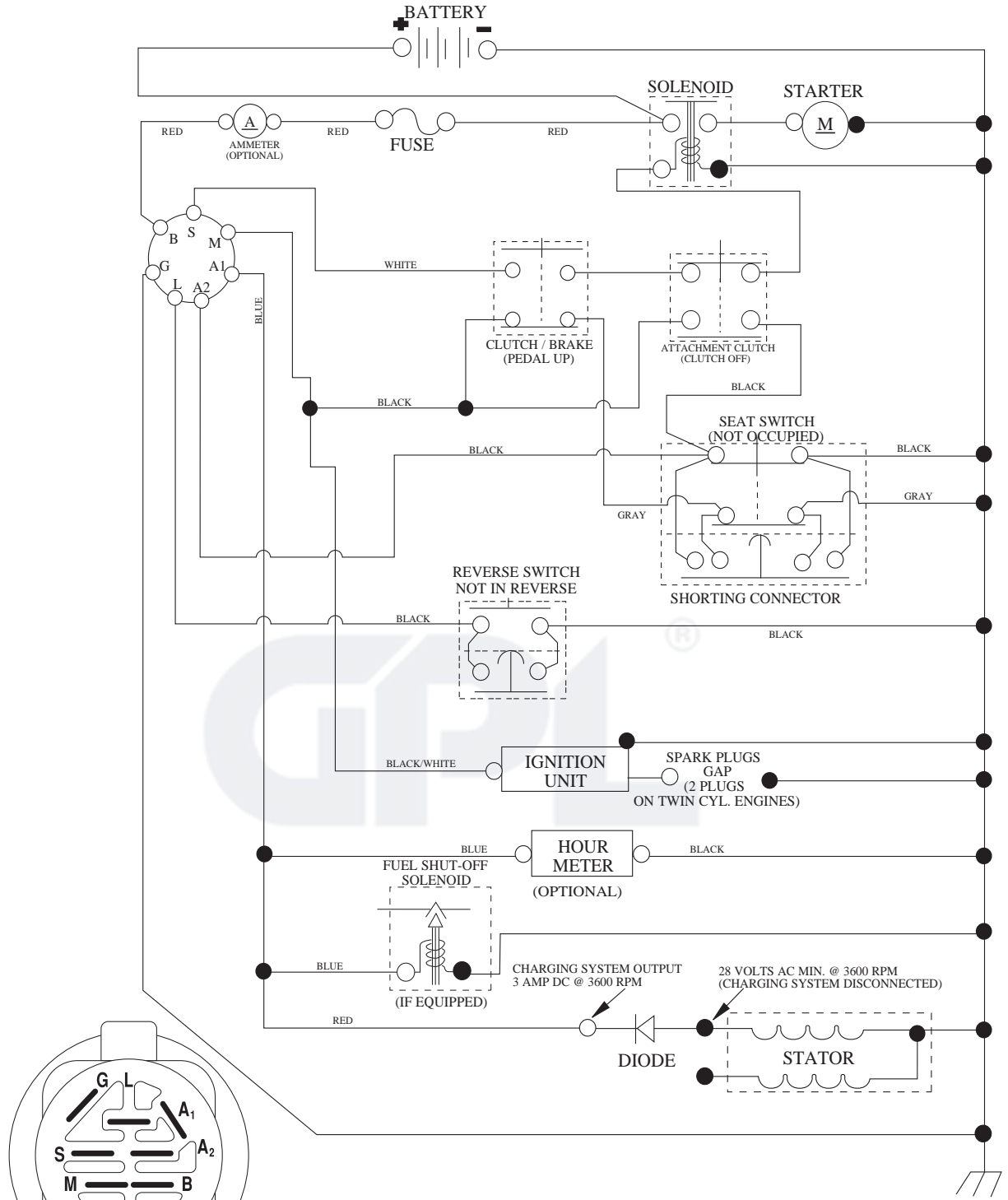

IGNITION SWITCH

POSITION	CIRCUIT "MAKE"
OFF	M+G+A1
RUN/OVERRIDE	B+A1
RUN	B+A1 L+A2
START	B + S + A1

WIRING INSULATED CLIPS  
NOTE: IF WIRING INSULATED CLIPS WERE REMOVED FOR SERVICING OF UNIT, THEY SHOULD BE RE-INSTALLED TO PROPERLY SECURE YOUR WIRING.

○  
REMOVABLE CONNECTIONS

●  
NON-REMOVABLE CONNECTIONS

TRACTOR -- MODEL NUMBER M11597 (96011023409), PRODUCT NO. 960 11 02-34  
ELECTRICAL

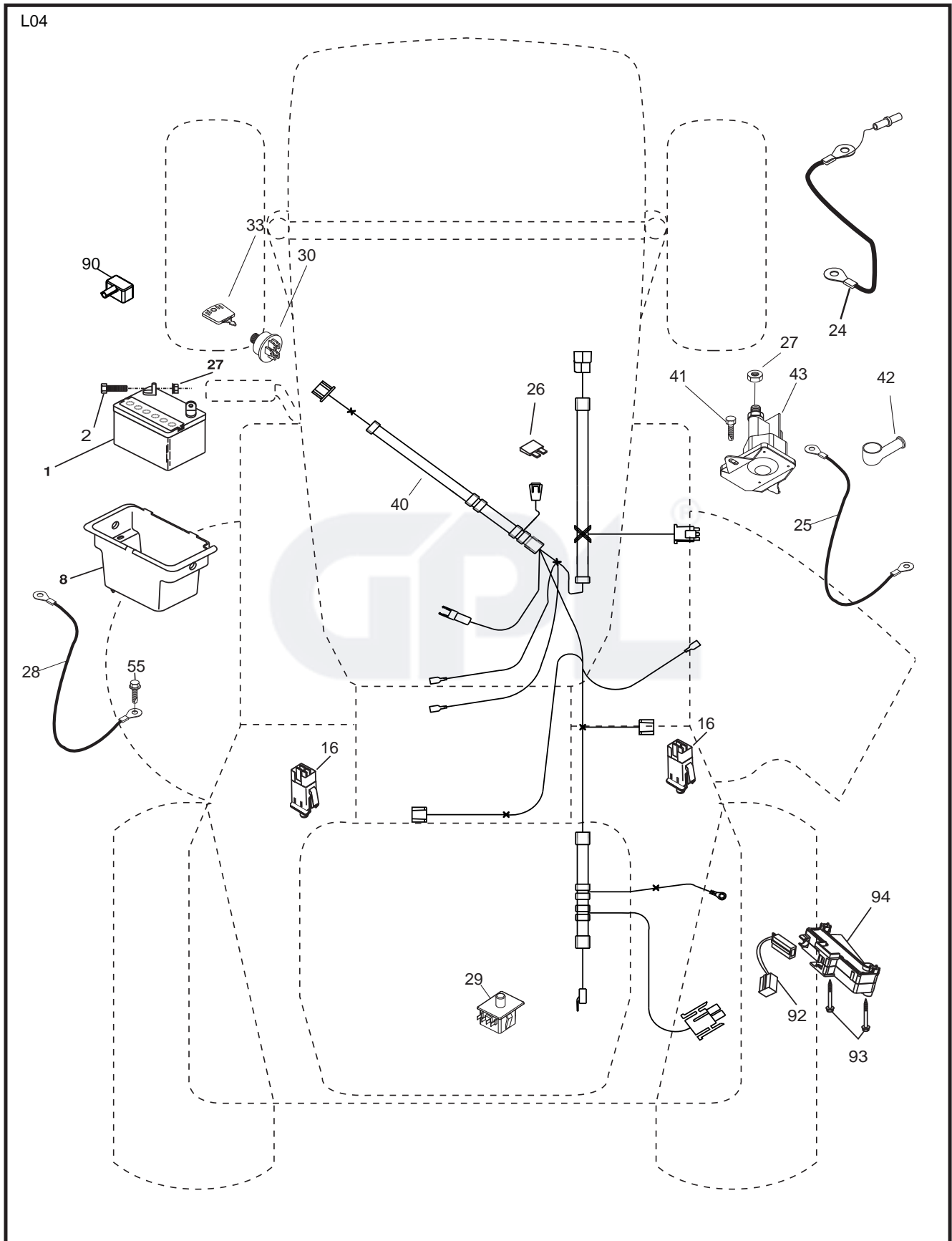

**TRACTOR -- MODEL NUMBER M11597 (96011023409), PRODUCT NO. 960 11 02-34  
ELECTRICAL**

<b>KEY NO.</b>	<b>PART NO.</b>	<b>DESCRIPTION</b>
1	532 14 49-24	Battery 20 Amp
2	874 76 04-12	Bolt Hex Hd 1/4-20 unc x 3/4
8	532 17 66-89	Battery Box
16	532 17 61-38	Switch Interlock Push-In
24	532 42 12-99	Cable Battery 6 Ga. 11" Red
25	532 42 12-97	Cable Battery
26	532 17 51-58	Fuse
27	873 51 04-00	Nut Keps Hex 1/4-20 unc
28	532 42 12-98	Cable Ground 6 Ga. 12" Black
29	532 19 27-49	Switch Seat
30	532 19 33-50	Switch Ign
33	532 41 19-35	Key/Chain
40	532 19 74-27	Harness Ign
41	871 11 04-08	Bolt Blk Fin Hex 1/4-20
42	532 13 15-63	Cover Terminal Red
43	532 19 25-07	Solenoid
55	817 00 06-12	Screw 3/8-16 x 3/4
90	532 43 53-95	Cover Terminal Battery
92	532 19 66-15	Harness Pigtail Consle ROS
93	532 19 25-40	Screw Plastite 10-14 x 2.0
94	532 19 18-34	Module Reverse ROS

**NOTE:** All component dimensions given in U. S. inches  
1 inch = 25.4 mm.

**TRACTOR -- MODEL NUMBER M11597 (96011023409), PRODUCT NO. 960 11 02-34  
CHASSIS AND ENCLOSURES**

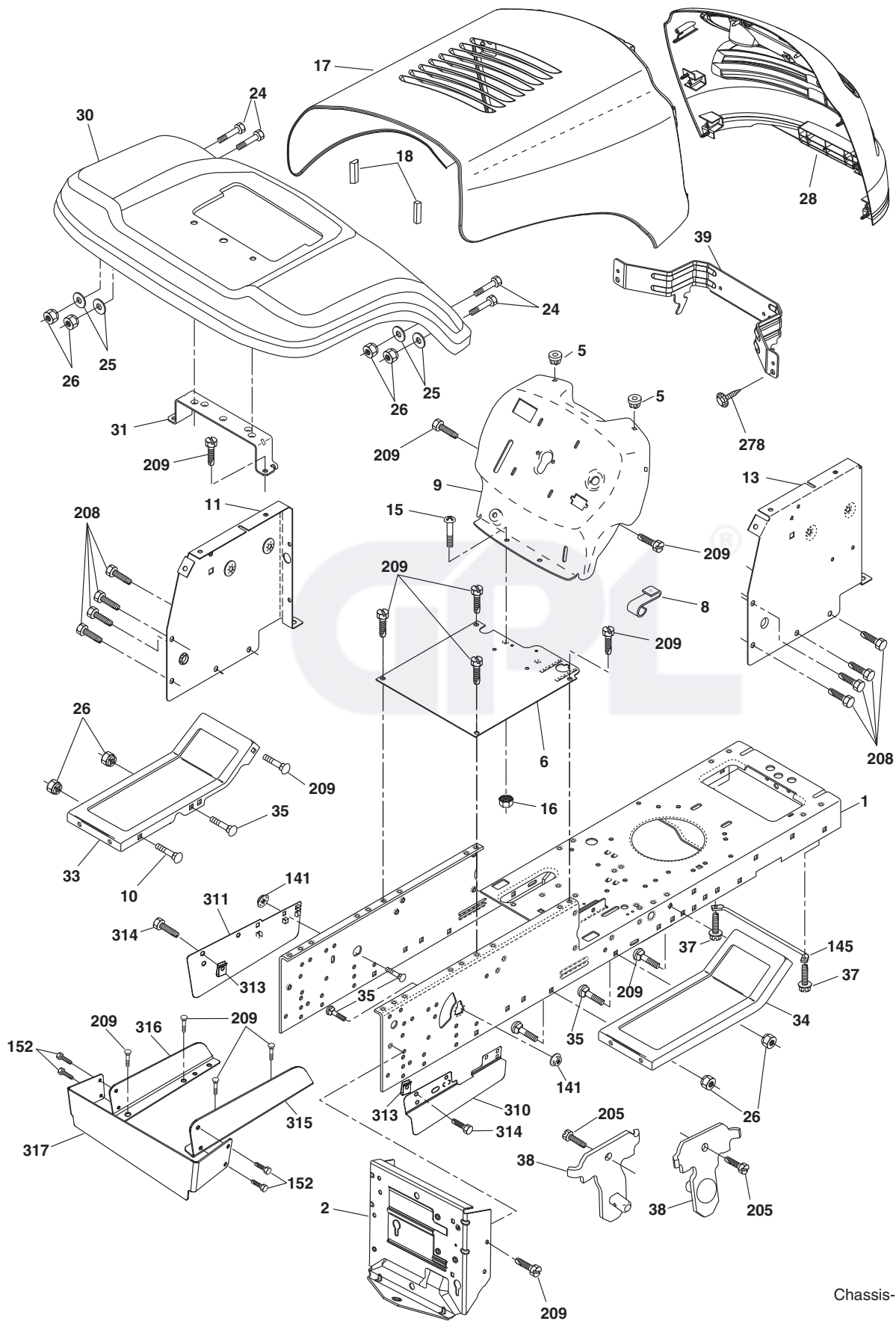

**TRACTOR -- MODEL NUMBER M11597 (96011023409), PRODUCT NO. 960 11 02-34  
CHASSIS AND ENCLOSURES**

<b>KEY NO.</b>	<b>PART NO.</b>	<b>DESCRIPTION</b>
1	532 17 46-20	Chassis
2	532 17 65-54	Drawbar
5	532 15 52-72	Bumper, Hood/Dash
6	532 18 44-19	Saddle
8	532 15 51-38	Clip, Retainer
9	532 19 46-88	Dash
10	872 14 06-08	Bolt, Carriage 3/8-16 x 1
11	532 17 49-96	Panel Dash LH
13	532 18 17-19	Panel, Silkscr Dash RH
15	874 18 05-12	Screw 5/16-18 x 3/4
16	873 51 05-00	Nut Keps 5/16-18 x 3/4
17	532 40 61-79	Hood
18	532 18 49-21	Bumper Hood
24	874 78 06-16	Bolt Fin Hex 3/8-16 unc x 1 Gr. 5
25	819 13 13-12	Washer 13/32 x 13/16 x 12 Ga.
26	873 80 06-00	Nut Lock Hex w/Ins 3/8-16 unc
28	532 44 03-57	Grille
30	532 40 48-52	Fender
31	532 13 66-19	Bracket Fender Repl 109873x
33	532 18 25-07	Footrest Pnt LH
34	532 18 25-08	Footrest Pnt RH
35	872 11 06-06	Bolt Rdhd Sht Sqnk 3/8-16 x 3/4
37	817 49 05-08	Screw Thdrol 5/16-18 x 1/2 TYT
38	532 17 57-10	Bracket Asm. Pivot Mower Rear
39	532 18 75-68	Bracket Pivot
141	873 90 06-00	Nut Lock Flg 3/8-16 unc
145	532 40 91-67	Rod Pivot Chassis/Hood
152	817 72 04-08	Screw THd Cut 1/4-20 x 1/2
205	817 49 06-08	Screw Thdrol 3/8-16 x 1/2
208	817 67 06-08	Screw Thdrol 3/8-16 x 1/2
209	817 00 06-12	Screw Hex Wsh Thdrol 3/8-16
278	532 41 63-58	Screw 10 x .750 BOS Thread
310	532 42 27-66	Shield Lower RH
311	532 42 27-67	Shield Lower LH
313	532 19 66-88	Clips Threaded
314	532 13 77-29	Screw Thd Roll 1/4-20 x 5/8
315	532 42 27-71	Shield Upper RH
316	532 42 27-72	Shield Upper LH
317	532 42 28-60	Shield Rear
--	532 19 39-35	Plug Switch Light
--	532 00 54-79	Plug Button Blk 359 Dia Choke

**NOTE:** All component dimensions given in U.S. inches  
1 inch = 25.4 mm.

TRACTOR -- MODEL NUMBER M11597 (96011023409), PRODUCT NO. 960 11 02-34  
DRIVE

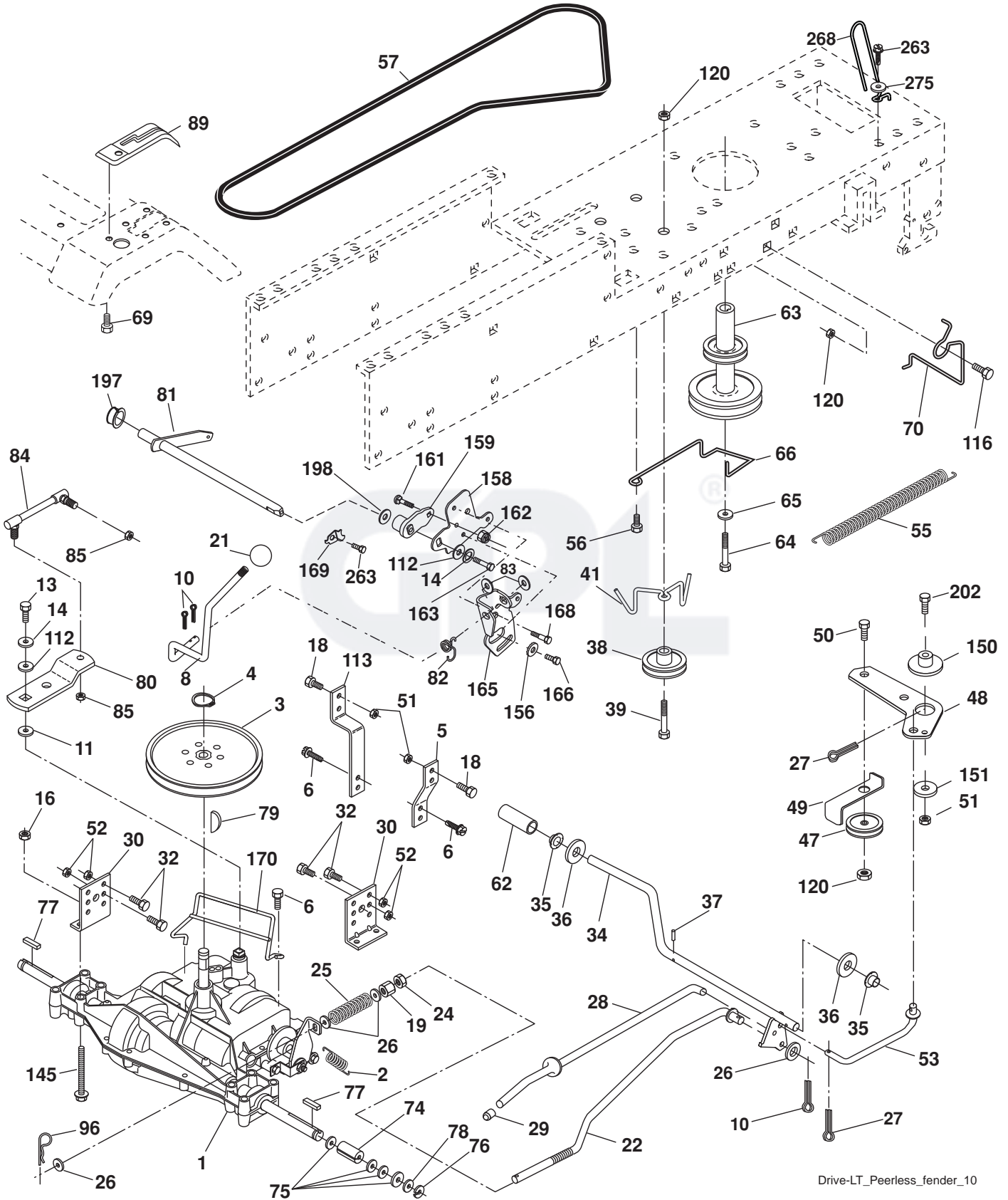

Drive-LT\_Peerless\_fender\_10

# TRACTOR -- MODEL NUMBER M11597 (96011023409), PRODUCT NO. 960 11 02-34 DRIVE

KEY NO.	PART NO.	DESCRIPTION	KEY NO.	PART NO.	DESCRIPTION
1	-----	Transaxle, Peerless 205-544C	70	532 13 46-83	Guide Belt Mower Drive RH
2	532 14 66-82	Spring Return Brake T/A Zinc	74	532 13 70-57	Spacer Axle
3	532 12 36-66	Pulley Transaxle 18" Tires	75	532 12 17-49	Washer 25/32 x 1 1/4 x 16 Ga.
4	812 00 00-28	Ring Retainer # 5100-62	76	812 00 00-01	E-ring #5133-75
5	532 12 15-20	Strap Torque 30 Degrees	77	532 12 35-83	Key Square 2 0 x 1845/ 1865
6	817 06 05-12	Screw 5/16-18 x 3/4	78	532 12 17-48	Washer 25/32 x 1-5/8 x 16 Ga.
8	532 19 27-06	Rod Shifter	79	532 12 50-96	Key Woodruff
10	876 02 04-16	Pin Cotter 1/8 x 1 Cad	80	532 13 14-86	Arm Shift Transaxle
11	532 10 57-01	Washer Plate Shf 388 Sq Hole	81	532 16 55-94	Shaft Asm. Cross Taper
13	874 55 04-12	Bolt 1/4-28 unf Gr. 8 w/Patch	82	532 16 57-11	Spring Torsion Shift
14	810 04 04-00	Washer Lock Hvy Helical 1/4	83	819 17 12-16	Washer 17/32 x 3/4 x 16 Ga.
16	873 80 05-00	Nut Lock Hx w/Ins 5/16-18 unc	84	532 16 62-28	Link Transaxle
18	874 78 06-16	Bolt, Fin Hex 3/8-16 unc x 1 Gr. 5	85	532 15 03-60	Nut Lock Center 1/4-28
19	873 80 06-00	Nut Lock 3/8-16 unc	89	532 19 49-71	Console, SVC Shift
21	532 10 69-33	Knob	96	532 12 47-88	Retainer Spring 1"
22	532 13 08-04	Rod Brake Blk Zinc 26 840	112	819 09 12-10	Washer 9/32 x 3/4 x 10 Ga.
24	873 35 06-00	Nut Hex Jam 3/8-16 unc	113	532 12 72-85	Strap Torque LH
25	532 10 68-88	Spring Rod Brake 2 00 Zinc	116	872 14 06-08	Bolt Rdhd Sq Neck 3/8-16 x 1.00
26	819 13 13-16	Washer 13/32 x 13/16 x 16 Ga.	120	873 90 06-00	Nut Lock Flg 3/8-16
27	876 02 04-12	Pin Cotter 1/8 x 3/4 Cad	145	874 49 05-40	Bolt Hex 5/16-18 x 2-1/2 Gr. 5
28	532 17 57-65	Rod Brake Parking	150	532 17 54-56	Spacer Retainer
29	532 07 16-73	Cap Brake Parking	151	819 13 32-10	Washer 13/32 x 2 x 10
30	532 17 49-73	Bracket Mtg Transaxle	156	532 16 60-02	Washer Srrtd 5/16 ID x 1.0 x .125TK
32	874 76 05-12	Bolt Hex Hd 5/16-18 unc x 3/4	158	532 43 74-58	Bracket Shift Mount
34	532 17 55-78	Shaft Asm Pedal Foot	159	532 18 39-00	Hub Shift
35	532 12 01-83	Bearing Nylon Blk 629 ID	161	872 14 04-06	Bolt RDHD SQNK 1/4-20 x 3/4 Gr.5
36	819 21 16-16	Washer 21/32 x 1 x 16 Ga.	162	873 68 04-00	Nut Crownlock 1/4-20 unc
37	532 12 49-63	Pin Roll 3/16 x 1"	163	874 78 04-16	Bolt Hex Fin 1/4-20 unc x 1 Gr. 5
38	532 17 91-14	Pulley Idler Composite	165	532 43 82-50	Bracket Pivot Lever
39	872 11 06-22	Bolt Rdhd 3/8-16 unc x 2-3/4 Gr. 5	166	817 49 05-10	Screw 5/16-18 x 5/8 TT Yellow
41	532 17 55-56	Keeper Belt Retainer Idler	168	532 16 54-92	Shoulder Bolt 5/16 -18 x .561
47	532 12 77-83	Pulley Idler V Groove Plastic	169	532 16 55-81	Plate, Fastening
48	532 15 44-07	Bellcrank Asm	170	532 18 74-14	Keeper Belt T/A
49	532 12 32-05	Retainer Belt Style Spring	197	532 16 96-13	Nyliner Snap-in 5/8" ID
50	872 11 06-12	Bolt Carr Sh 3/8-16 x 1-1/2 Gr. 5	198	532 16 98-45	Washer Nyl
51	873 68 06-00	Nut Crownlock 3/8-16 unc	202	872 11 06-14	Bolt, 3/8-16 x 1-3/4 Gr. 5
52	873 68 05-00	Nut Crownlock 5/16-18 unc	263	817 00 06-12	Screw, 3/8-16 x 3/4
53	532 19 96-52	Link Clutch	268	532 18 24-02	Guard, Muffler
55	532 10 57-09	Spring Return Clutch 675	275	819 13 16-14	Washer, 13/32 x 1 x 14 Ga.
56	817 06 06-20	Screw 3/8-16 x 1-1/4			
57	532 13 82-55	V-Belt Ground Drive			
62	532 12 48-72	Cover Pedal Blk Round			
63	532 17 54-10	Engine Pulley			
64	532 17 39-37	Bolt Hex			
65	810 04 07-00	Washer Lock Hvy Hlcl Spr 7/16			
66	532 15 47-78	Keeper Belt Engine Foolproof			
69	532 14 24-32	Screw Hex Wsh Hi-Lo 1/4 x 1/2 unc			

**NOTE:** All component dimensions given in U.S. inches  
1 inch = 25.4 mm

**TRACTOR -- MODEL NUMBER M11597 (96011023409), PRODUCT NO. 960 11 02-34  
ENGINE**

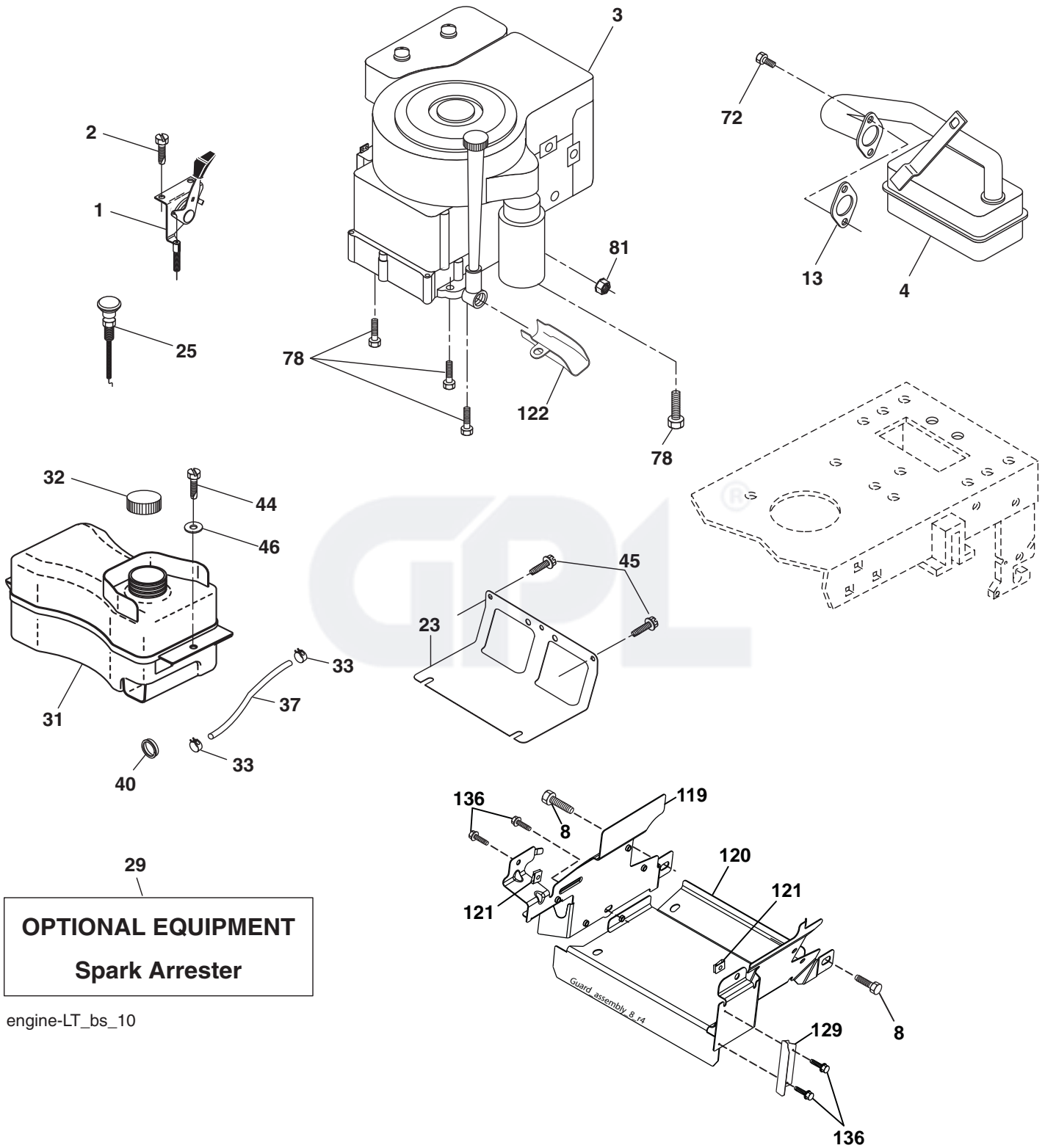

**OPTIONAL EQUIPMENT**  
**Spark Arrester**

engine-LT\_bs\_10

# TRACTOR -- MODEL NUMBER M11597 (96011023409), PRODUCT NO. 960 11 02-34 ENGINE

KEY NO.	PART NO.	DESCRIPTION
1	532 17 05-51	Control Throttle / Choke
2	817 72 04-08	Screw Hex Thd Cut 1/4-20 x 5/8 T
3	532 43 86-12	Engine Briggs Model 217807-3391-B1
4	532 17 97-58	Muffler Exhaust
8	532 17 18-77	Bolt 5/16 - 18 unc x 3/4
13	532 16 52-91	Gasket
23	532 16 98-37	Shield Browning/Debris Guard
25	532 19 06-95	Control, Choke
29	532 13 71-80	Arrester Spark
31	532 40 75-16	Tank Fuel
32	532 43 02-20	Cap Fuel
33	532 12 34-87	Clamp Hose Blk
37	532 13 70-40	Line Fuel 20"
40	532 12 40-28	Bushing Snap
44	817 67 04-12	Screw Hexwsh Thdrol 3/8-16 x 3/4
45	817 00 06-12	Screw 3/8-16 x 3/4
46	819 09 14-16	Washer 9/32 x 7/8 x 16 Ga.
72	532 19 23-34	Screw Socket Hd 5-16-18 x .75
78	817 06 06-20	Screw 3/8-16 x 1-1/4
81	873 51 04-00	Nut Keps Hex 1/4-20 unc
119	532 19 79-49	Guard Pulley Eng. LH
120	532 19 79-48	Guard Pulley Eng. RH
121	532 19 66-88	Clips Threaded
122	532 42 19-22	Screw 1/4 - 20 x 5/8
129	532 40 03-28	Guard Pulley Eng. Adapter
136	532 13 77-29	Screw 1/4 - 20 x 5/8

**NOTE:** All component dimensions given in U.S. inches  
1 inch = 25.4 mm

## Engine Power Rating Information

The gross power rating for individual gas engine models is labeled in accordance with SAE (Society of Automotive Engineers) code J1940 (Small Engine Power & Torque Rating Procedure), and rating performance has been obtained and corrected in accordance with SAE J1995 (Revision 2002-05). Torque values are derived at 3060 RPM; horsepower values are derived at 3600 RPM. Actual gross engine power will be lower and is affected by, among other things, ambient operating conditions and engine-to-engine variability. Given both the wide array of products on which engines are placed and the variety of environmental issues applicable to operating the equipment, the gas engine will not develop the rated gross power when used in a given piece of power equipment (actual "on-site" or net power). This difference is due to a variety of factors including, but not limited to, accessories (air cleaner, exhaust, charging, cooling, carburetor, fuel pump, etc.), application limitations, ambient operating conditions (temperature, humidity, altitude), and engine-to-engine variability. Due to manufacturing and capacity limitations, Briggs & Stratton may substitute an engine of higher rated power for this Series engine.

**TRACTOR -- MODEL NUMBER M11597 (96011023409), PRODUCT NO. 960 11 02-34**  
**STEERING**

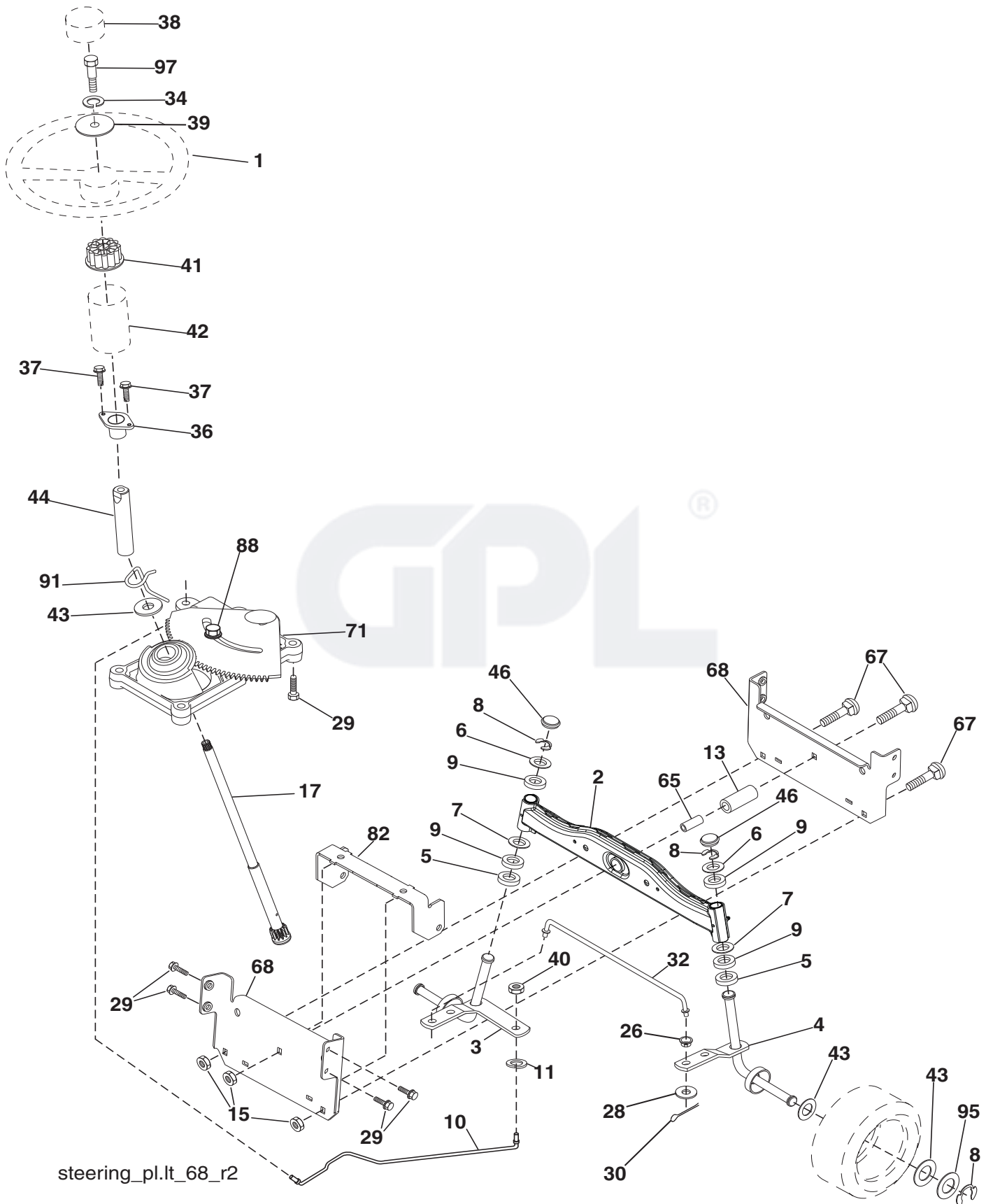

**TRACTOR -- MODEL NUMBER M11597 (96011023409), PRODUCT NO. 960 11 02-34  
STEERING**

<b>KEY NO.</b>	<b>PART NO.</b>	<b>DESCRIPTION</b>
1	532 42 45-43	Wheel Steering
2	532 41 81-68	Axle Asm
3	532 16 98-40	Spindle Asm LH
4	532 16 98-39	Spindle Asm RH
5	532 12 49-31	Washer Thrust
6	532 12 17-48	Washer 25/32 x 1-5/8 x 16 Ga.
7	819 27 20-16	Washer 27/32 x 1-1/4 x 16 Ga.
8	812 00 00-29	Ring Klip #t5304-75
9	532 12 49-37	Bearing Col Strg Blk
10	532 17 51-21	Link Drag
11	810 04 06-00	Washer Lock Hvy Hlcl Spr 3/8
13	532 13 65-18	Spacer earing Axle Front
15	873 90 06-00	Nut Lock Flg. 3/8-16 unc
17	532 19 07-53	Shaft Asm Strg
26	532 12 68-47	Bushing Link Drag Blk LR
28	819 13 14-16	Washer 13/32 x 7/8 x 16 Ga.
29	817 00 06-12	Screw 3/8-16 x 3/4
30	876 02 04-12	Pin Cotter 1/8 x 3/4 Cad
32	532 19 27-57	Rod Tie Wire Form 19 75 Mech
34	810 04 05-00	Washer Lock 5/16
36	532 15 50-99	Bushing Strg 5/8 ID Dash
37	532 15 29-27	Screw
38	532 42 41-47	Cap Wheel Steer
39	819 11 38-12	Washer 11/32 ID x 2 3/8 OD x 12 Ga.
40	873 54 06-00	Nut Crownlock 3/8-24
41	532 18 67-37	Adaptor Wheel Strg
42	532 16 96-33	Boot Steering
43	532 12 17-49	Washer 25/32 x 1 1/4 x 16 Ga.
44	532 19 07-52	Extension Steering
46	532 12 12-32	Cap Spindle Fr Top Blk
65	532 41 47-36	Spacer Brace Axle
67	872 11 06-18	Bolt RdHd Sqnk 3/8-16 x 2-1/4
68	532 16 98-27	Brace Axle
71	532 17 51-46	Steering Asm
82	532 19 99-78	Bracket Susp Chassis Front
88	532 17 51-18	Bolt shoulder 7/16-20
91	532 17 55-53	Clip Steering
95	532 18 89-67	Washer Hardened
97	532 42 89-82	Bolt Fin Hex 5/16-18 x 4 w/Patch

**NOTE:** All component dimensions given in U.S. inches  
1 inch = 25.4 mm.

# TRACTOR -- MODEL NUMBER M11597 (96011023409), PRODUCT NO. 960 11 02-34 MOWER DECK

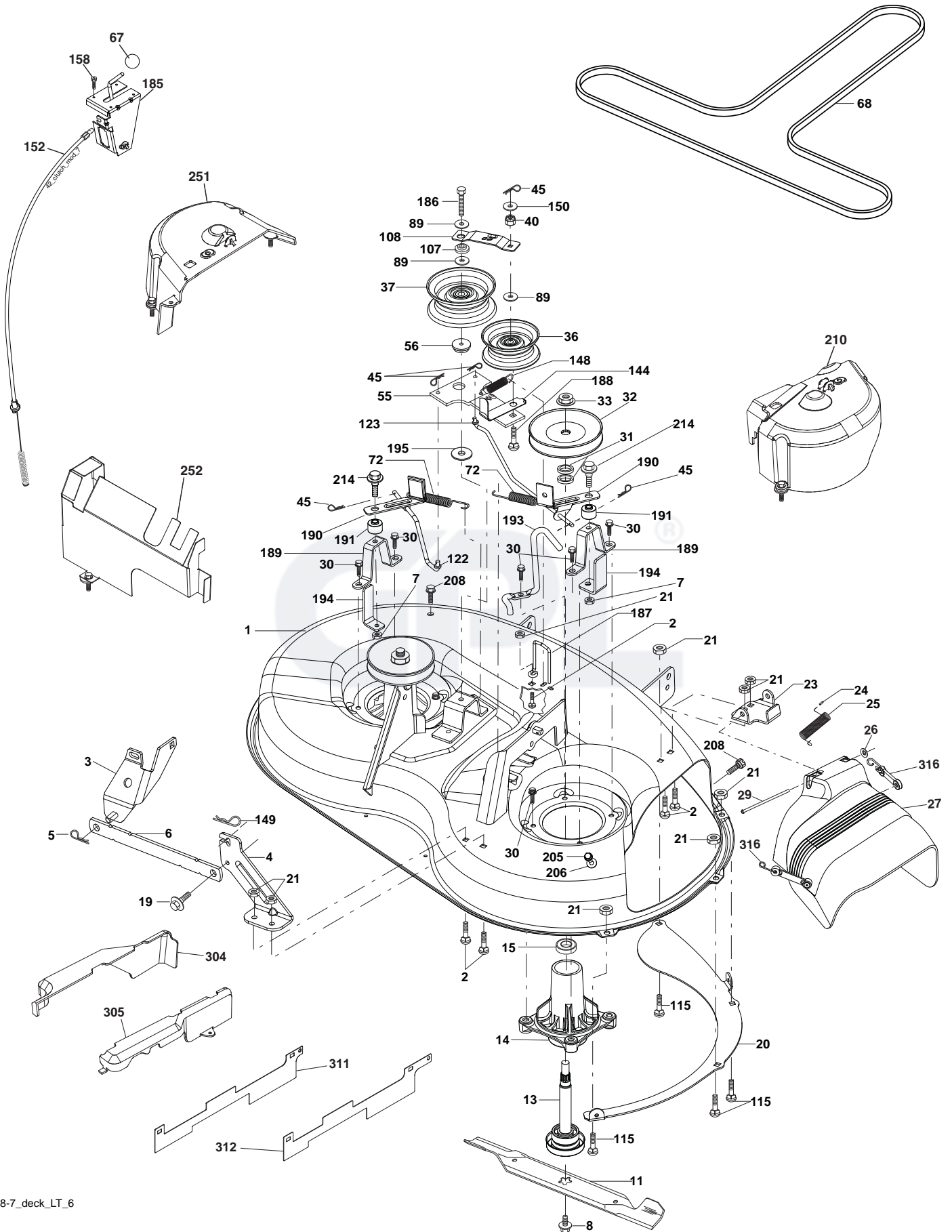

**TRACTOR -- MODEL NUMBER M11597 (96011023409), PRODUCT NO. 960 11 02-34  
MOWER DECK**

KEY NO.	PART NO.	DESCRIPTION	KEY NO.	PART NO.	DESCRIPTION
1	532 19 25-56	Mower Housing Assembly	150	819 09 12-10	Washer 9/32 x 3/4 x 10 Ga.
2	872 14 05-06	Bolt Carriage 5/16-18 x 3/4	152	532 19 32-35	Clutch Cable 38"/46"
3	532 13 80-17	Bracket Asm Fr. Sway Bar	158	817 72 04-08	Screw Hex Thd Cut 1/4-20 x 1/2
4	532 19 25-68	Bracket Deck Sway Bar 38"/42"	185	532 18 82-34	Head Asm Cable Clutch
5	532 12 46-70	Retainer Spring	186	817 49 06-44	Screw Hex Wsh Thdrol 3/8-16 x 2-3/4
6	532 17 80-24	Bar Sway Deck	187	532 19 34-12	Keeper Belt
7	873 80 05-00	Nut Lock Hex w/Ins. 5/16-18 unc	188	532 16 58-91	Bolt Carriage Idler
8	532 19 30-03	Bolt 3/8-24 x 1.25 Gr. 8	189	532 19 25-59	Stand, Brake
11	532 19 39-57	Blade Mower	190	532 19 25-60	Arm, Brake
13	532 19 28-72	Shaft Assembly, Mandrel, Vented	191	532 19 25-61	Spacer, Brake
14	532 18 72-81	Housing, Mandrel, Vented	193	532 19 34-13	Keeper Belt Rh Mandrel
15	532 11 04-85	Bearing, Ball, Mandrel	194	532 19 41-05	Guard Brake
19	532 13 28-27	Bolt, Shoulder	195	819 13 32-10	Washer
20	532 40 00-95	Baffle Vortex Front	205	817 49 04-16	Screw 1/4 - 20 x 1.0077
21	873 68 05-00	Nut	206	819 09 14-16	Washer 9/32 x 7/8 x 16 Ga.
23	532 19 25-57	Bracket, Mower Deflector	208	817 67 06-08	Screw 3/8 - 16 x 1/2
24	532 10 53-04	Cap, Sleeve	210	532 43 23-57	Cover Asm. RH
25	532 19 70-26	Spring, Torsion, Deflector	214	532 19 37-82	Bolt/Washer Asm 5/16-18
26	532 11 04-52	Nut, Push	251	532 43 23-56	Cover Asm. LH
27	532 40 16-18	Shield, Deflector	252	532 43 23-55	Cover Rear Asm.
29	532 13 14-91	Rod, Hinge	304	532 43 23-58	Shield, Side LH Asm.
30	532 17 39-84	Screw Thdrol.	305	532 43 23-59	Shield, Side RH Asm.
31	532 18 76-90	Washer, Spacer	311	532 43 02-27	Shield DCK inside LH
32	532 15 35-32	Pulley, Mandrel	312	532 43 02-25	Shield DCK inside RH
33	532 40 02-34	Nut, Toplock	316	532 43 60-87	Kit Bungee
36	532 13 14-94	Pulley, Idler, Flat	--	532 19 25-58	Brake Assembly (Includes Stand, Arm and Guard Components)
37	532 19 31-98	Pulley Idler Flat	--	532 19 28-70	Mandrel Assembly (Includes Housing, Shaft and Shaft Hardware Only - Pulley Not Included)
40	873 68 06-00	Nut, Crownlock 3/8-16 unc	--	532 43 18-41	Replacement Mower, Complete
45	532 12 47-88	Retainer Spring			
55	532 13 38-40	Idler Arm Assembly			
56	532 16 57-23	Spacer, Retainer			
67	532 10 69-32	Knob			
68	532 19 32-14	V-Belt			
72	532 19 32-16	Spring Brake Return			
89	819 13 13-11	Washer 13/32 x 13/16 x 11 Ga.			
107	532 13 35-02	Spacer Retainer			
108	532 13 35-03	Stiffener, Idler Arm			
115	872 14 05-05	Bolt 5/16-18 x 5/8			
122	532 41 01-89	Rod, Brake LH			
123	532 41 01-90	Rod, Brake RH			
144	532 19 34-14	Keeper Belt Idler Tension			
148	532 16 90-22	Spring Return Idler			
149	532 16 58-98	Retainer Spring Yellow			

**NOTE:** All component dimensions given in U.S. inches  
1 inch = 25.4 mm

**TRACTOR -- MODEL NUMBER M11597 (96011023409), PRODUCT NO. 960 11 02-34  
MOWER LIFT**

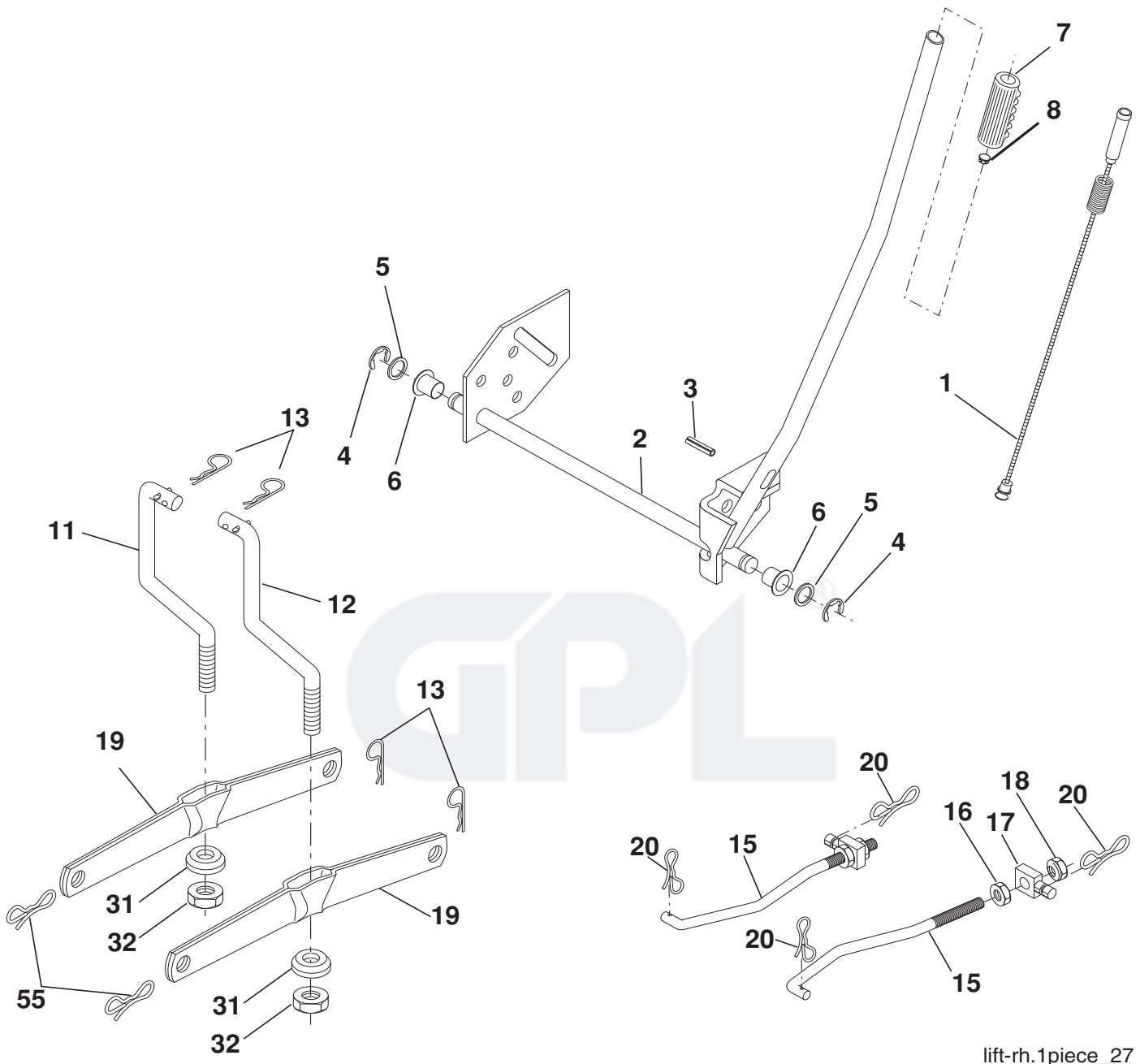

lift-rh.1piece\_27

KEY NO.	PART NO.	DESCRIPTION
1	532 40 49-81	Plunger Asm Lift Lvr
2	532 15 94-71	Shaft Asm Lift RH
3	532 10 57-67	Pin Groove
4	812 00 00-02	E Ring #5133-62
5	819 21 16-21	Washer 21/32 x 1 x 21 Ga.
6	532 12 01-83	Bearing Nylon Blk 629 ID
7	532 10 94-13	Grip Handle Bicycle Matte Blk
8	532 12 45-26	Button Plunger Black
11	532 13 98-65	Link Lift LH Fixed Length
12	532 13 98-66	Link Lift RH Fixed Length
13	532 12 46-70	Retainer Spring
15	532 17 32-88	Link Front

KEY NO.	PART NO.	DESCRIPTION
16	873 35 08-00	Nut Jam Hex 1/2-13 unc
17	532 17 56-89	Trunnion
18	873 80 08-00	Nut Lockw/Wsh 1/2-13 unc
19	532 13 98-68	Arm Suspension Rear
20	532 19 42-09	Retainer, Spring
31	532 16 98-65	Bearing Pvt Lift
32	873 54 06-00	Nut Crownlock 3/8-24
55	532 19 42-08	Bow Tie Lock

**NOTE:** All component dimensions given in U.S. inches  
1 inch = 25.4 mm.

**TRACTOR -- MODEL NUMBER M11597 (96011023409), PRODUCT NO. 960 11 02-34 SEAT**

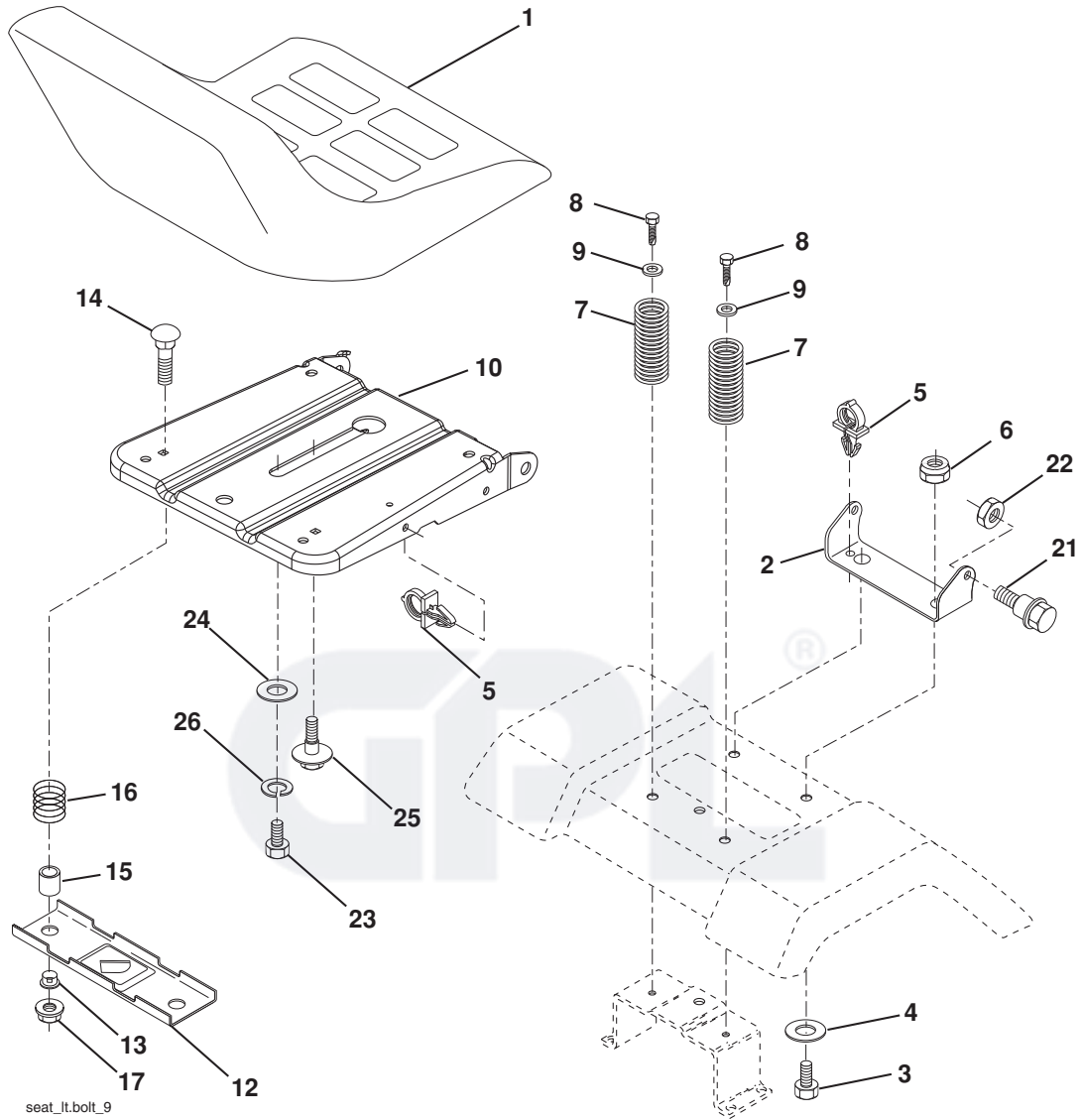

seat\_lt.bolt\_9

KEY NO.	PART NO.	DESCRIPTION
1	532 40 10-42	Seat
2	532 14 05-51	Bracket Seat Pivot
3	871 11 06-16	Bolt Hex 3/8 - 16 x 1
4	819 13 16-10	Washer 13/32 x 1 x 10 Ga.
5	532 14 50-06	Clip Push-In Hinged
6	873 80 06-00	Nut Lock Hex w/Ins 3/8 - 16
7	532 12 41-81	Spring Seat Cprsn 2 250 Blk Zi
8	817 00 06-16	Screw 3/8-16 x 1.5
9	819 13 16-14	Washer 13/32 x 1 x 14 Ga.
10	532 19 55-30	Pan Pnt Seat (Blk)
12	532 17 46-48	Bracket Pnt Mounting Switch
13	532 12 12-48	Bushing Snap Blk Nyl

KEY NO.	PART NO.	DESCRIPTION
14	872 05 04-12	Bolt Rdhd Sht Nk 1/4 - 20 x 1 -1/2
15	532 13 43-00	Spacer Split .28 x .96
16	532 12 12-50	Spring Cprsn
17	532 12 39-76	Nut Lock 1/4 Lge Flg
21	532 17 18-52	Bolt Shoulder 5/16-18 unc-2A
22	873 80 05-00	Nut Lock Hex w/Ins 5/16 - 18
23	871 11 08-14	Bolt Hex Black
24	819 17 19-12	Washer 17/32 x 1-3/16 x 12 Ga.
25	532 12 70-18	Bolt Shoulder 5/16-18 x .62
26	810 04 08-00	Washer Lock

**NOTE:** All component dimensions given in U.S. inches  
1 inch = 25.4 mm.

**TRACTOR -- MODEL NUMBER M11597 (96011023409), PRODUCT NO. 960 11 02-34  
DECALS**

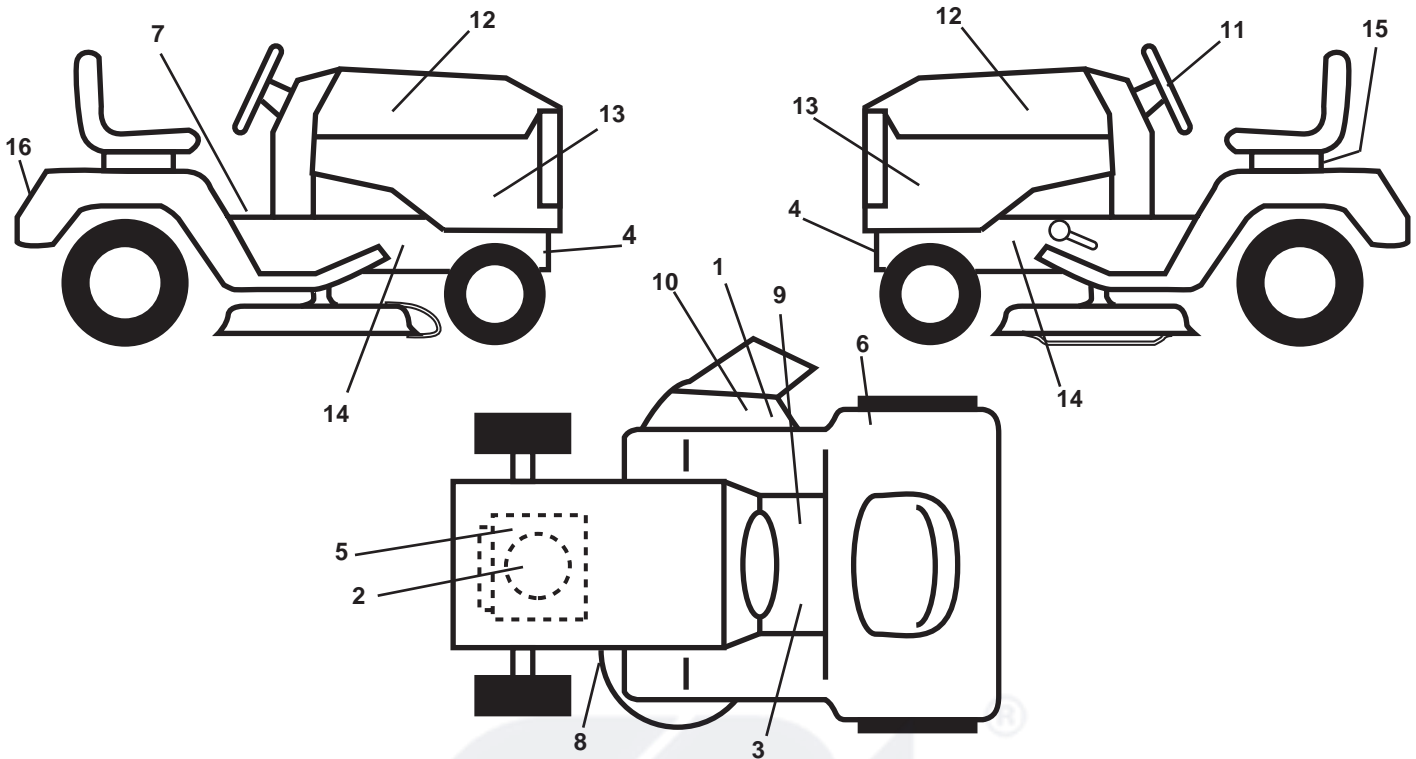

KEY NO.	PART NO.	DESCRIPTION
1	532 19 63-57	Decal, Deflect Wrn Cutfinger Sym
2	532 43 74-09	Decal Engine HP
3	532 15 97-37	Decal, Brake/Clutch
4	532 15 97-36	Decal, Hot Muffler
5	532 19 68-41	Decal, Warning Engine Sym
6	532 18 04-32	Decal, DBA
7	532 40 03-89	Decal, Read Owner's Manual
8	532 19 43-02	Decal, V-Belt Sch.
9	532 14 08-37	Decal, Parking Brake
10	532 18 21-66	Decal, Cut Finger
11	532 43 79-66	Decal, Strg. Wheel

KEY NO.	PART NO.	DESCRIPTION
12	532 43 82-71	Decal, Hood RH/LH
13	532 43 85-28	Decal, Hood Side Panel
14	532 40 11-46	Decal, Warning Serv/Fire
15	532 14 50-05	Decal, Caution, Battery
--	532 43 78-33	Decal, Fender
--	532 16 25-98	Decal, Drawbar
--	532 13 83-11	Decal, Handle Lft Height Adj.
--	532 44 02-77	Manual, Operator's, Euro.
--	532 44 02-78	Manual Parts

**WHEELS & TIRES**

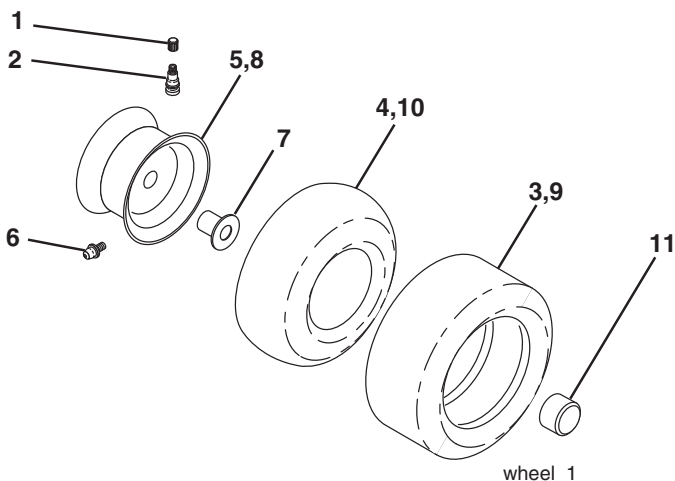

KEY NO.	PART NO.	DESCRIPTION
1	532 05 91-92	Cap, Tire valve
2	532 06 51-39	Stem, Valve
3	532 10 62-22	Tire, Front
4	532 05 99-04	Tube, Front (Service item only)
5	532 12 51-21	Rim assembly, 6" Front
6	532 12 49-57	Fitting, Grease (Front wheel only)
7	532 12 49-59	Bearing, Flange (Front wheel only)
8	532 12 51-22	Rim assembly, 8" Rear
9	532 12 46-35	Tire, Rear
10	532 12 49-26	Tube, Rear (Service item only)
11	532 17 50-39	Cap, Hub Axle
--	532 14 43-34	Sealant, Tire (10 oz. Tube)

**NOTE:** All component dimensions given in U.S. inches  
1 inch = 25.4 mm

---

# SERVICE NOTES

---



GPL®